

Original user manual

Two-piece swaging tool

Oetiker Compact XL For Multi Crimp Rings PG 150

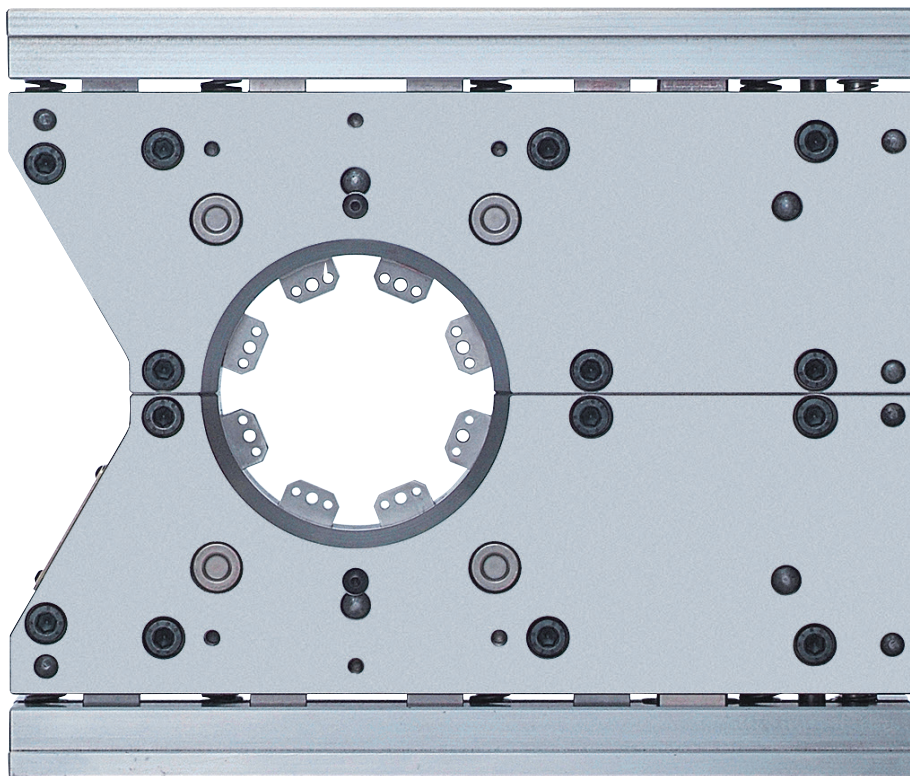

Connecting Technology

Contents

1	Product Description	3
	1.1 Introduction.....	3
	1.2 Designation.....	3
	1.3 Technical Data	4
2	Safety Instructions	5
	2.1 Danger, Warning	5
	2.2 Intended Use	5
	2.3 Modifications and Damage to the Swaging Tool.....	5
	2.4 User Requirements / Operating Personnel	5
	2.5 General Danger Warnings.....	6
	2.6 Additional Directives	6
3	Tool Description	7
	3.1 Function	7
	3.2 Design	7
4	Installing the Swaging Tool.....	8
	4.1 Operational Location of the Swaging Tool	8
	4.2 Installing the Swaging Tool	8
	4.3 Testing Function	9
5	Operation	10
	5.1 User Requirements / Operating Personnel	10
	5.2 Swaging with the Swaging Tool	10
6	Maintenance	12
	6.1 Cleaning	12
	6.2 Exchanging the Swaging Jaws	12
	6.3 Check / Exchange Internal Parts.....	13
	6.4 Repair	14
7	Malfunctions and their Elimination.....	15
8	Packing, Transport, Storage	16
	8.1 Packing.....	16
	8.2 Transport.....	16
	8.3 Storage.....	16
9	Disposal	17
10	Spare Parts	17
11	Statement of conformity.....	18
	11.1 EC Declaration.....	18

1 Product Description

1.1 Introduction



Warning

Operation of the swaging tool is prohibited until the external driving mechanism (e.g., a hydraulic press) into which the swaging tool is installed complies with the provisions of «Guidelines 98/37 EEC».

Be sure to observe the following directives:

- Please read this technical description thoroughly before you install the swaging tool in a press and before commissioning. Ensure that you are completely familiar with all the equipment and functions of both the press and Swaging tool.
- Strict compliance with the safety instructions of chapter 2, Safety Instructions is a prerequisite for safe, trouble-free operation.
- The swaging tool has been constructed for conventional use, see section 2.2, Intended Use. Any and all applications exceeding such usage are to be considered illegitimate. The manufacturer is not liable for any damages resulting from such illegitimate use; in such cases, the user alone is responsible.
- In order to ensure fast and correct supplies of spare parts, please provide the following particulars when ordering: product identifier, article number, serial number, quantity and name of the spare part, spare part number, shipping information (truck or train), exact delivery address.
- In our efforts to continually improve the quality of our products, we reserve the right to make improvements as long as these have no negative effects on use, and to do so without changing this technical description.

1.2 Designation

Product Identifier:	swaging tool OETIKER COMPACT XL
Article Number:	13401306
Serial Number:	See nameplate

Nameplate

The nameplate (1) is located on the sloping face of the swaging tool.

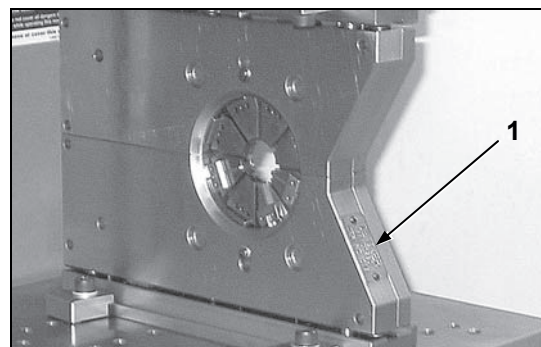

1.3 Technical Data

Swaging Tool

External dimensions (length x width x height):	385 x 58 x 330 mm
Weight:	35 kg
Material:	Steel
Tool-to-tool spacing:	min. 45 mm

Press data

Ring dimensions:	ø 16 to 109 mm
Ring widths:	7, 8, 9 and 10 mm
Swaging jaws stroke in ø:	8 mm

Minimal requirements for press

Press force:	min. 5000 kg
Press stroke	min. 94 mm
Press area (height x depth):	min. 394 x 250 mm
Upper pressure plate:	guided laterally

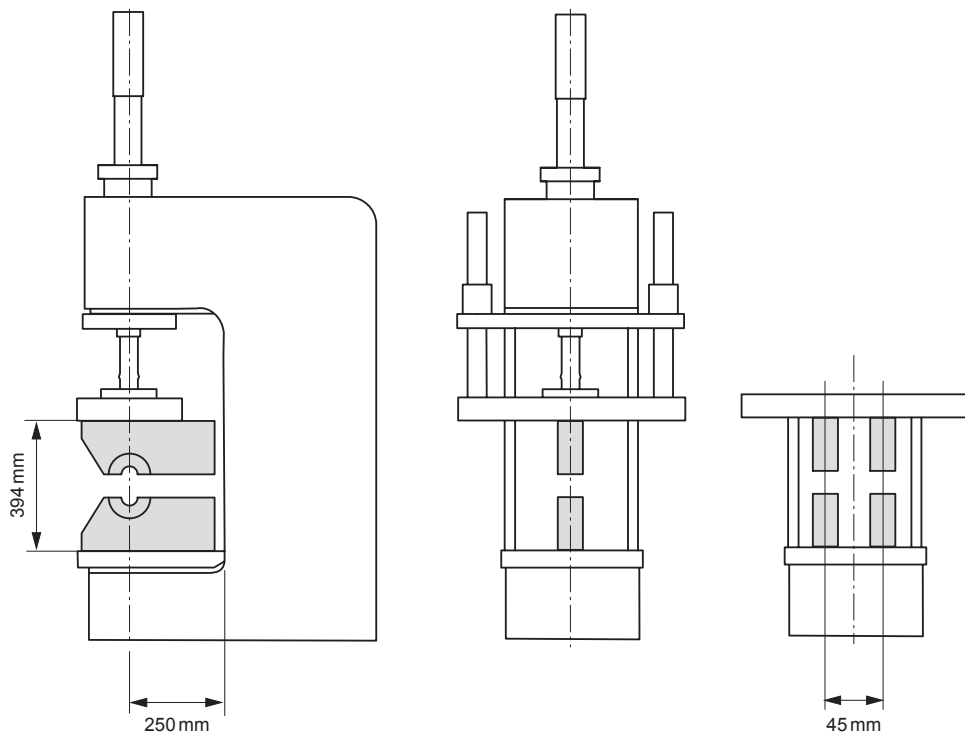

2 Safety Instructions

2.1 Danger, Warning

In this technical description, directives associated with possible dangers related to swaging tool handling are designated as follows:



Warning

This symbol indicates risk of injury to persons. The associated directives must be followed without exception!

2.2 Intended Use

- The swaging tool is a tool for swaging (pressing) OETIKER Multi Crimp Rings (MCR, PG 150).
- The swaging tool is only to be installed and operated in a press that meets the requirements of section 1.4, Technical Data.
- Uses extending beyond those specified are not permitted.
- The manufacturer or vendor is not liable for any associated damages or injuries if the swaging tool is used for applications other than those specifically designated herein! The user alone is responsible for the consequences.
- The swaging tool is built in accordance with the currently valid state of technology as well as the safety-related rules currently in effect.

2.2.1 Placement of the technical description

- This technical description is to be accessible always at the operational location of the swaging tool.
- This technical description is to be protected from contamination and damage.

2.3 Modifications and Damage to the Swaging Tool

- If the swaging tool has visible damage (e.g., to the swaging jaws), the swaging tool must not be operated and is to be taken out of service immediately.
- Never immerse the swaging tool in water or other fluids.
- Unauthorized modifications to the swaging tool exonerates the manufacturer from liability associated with any associated damages or injuries.

2.4 User Requirements / Operating Personnel

- The swaging tool is to be operated by qualified, trained personnel only. Such personnel must also be familiar with the safety instructions and operation of the press being used. The minimum age allowed by law is to be observed.
- Maintenance and repair work is to be carried out by qualified specialists only.
- Before commissioning the swaging tool, personnel authorized to work with the swaging tool are to have read and understood this technical description and to have been instructed concerning possible dangers.

2.5 General Danger Warnings

2.5.1 General Dangers when Working with Presses

The safety instructions provided in the operating instructions for the press are also to be observed without restriction when using the swaging tool.

2.5.2 General Dangers when Working with the Swaging Tool



Warning

Danger of injury (crushing of fingers/hands) between upper and lower halves of the swaging tool.
 Danger of injury (crushing of fingers/hands) in the area of the swaging jaws while pressing.
 Avoid any touching or other contact while pressing.



Warning

Danger of eye injury from metal splinters.
 Always wear safety glasses when working with the swaging tool.



Warning

Danger of hearing damage because of noise level.
 Always wear ear protection when working with the swaging tool.



2.5.3 Dangers Resulting from Non-observance of Safety Instructions

- Non-observance of the safety instructions can not only result in injury to personnel, but also to the environment and the swaging tool.
- Non-observance of the safety instructions can result in the loss of any damage claims.

2.6 Additional Directives

- In addition to the directives of this technical description, generally applicable, legal and other binding regulations for accident prevention as well as the generally acknowledged safety-related and industrial health regulations apply.
- Environmental regulations applicable within the country where the swaging tool is being used are to be observed.

3 Tool Description

3.1 Function

The swaging tool OETIKER COMPACT XL is used to swage (press or crimp) OETIKER Multi Crimp Rings (MCR, PG 150). It is operated by an external driving mechanism, e.g., an hydraulic press. The swaging tool OETIKER COMPACT XL can be lifted, thus allowing optimal workpiece placement. Eight exchangeable swaging jaws(closure segments) allow MCR diameter adjustments with minimal handling.

Workpieces as well as the associated MCR are manually inserted into the swaging tool OETIKER COMPACT XL.

3.2 Design

Pos.	Name
1	Upper half of tool
2	Pressure plate
3	Cover plate
4	Guide plate
5	Swaging jaws
6	Lower half of tool

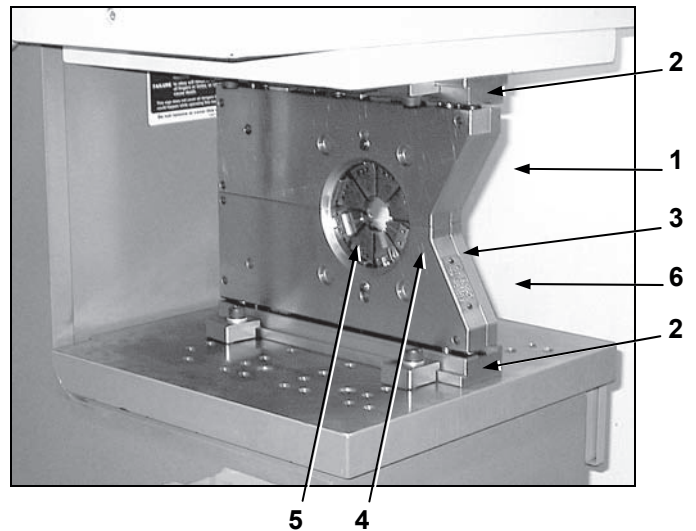

4 Installing the Swaging Tool



Warning

Whenever the swaging tool is installed in or removed from a press, ensure that the press cannot inadvertently be activated. Safety instructions for the press are to be fully observed at all times.

4.1 Operational Location of the Swaging Tool

The swaging tool is to be used in a conventional location set aside for machines (industrial operation). In no event is the swaging tool to be installed or placed in areas where acids or similar chemicals are stored.



Danger of Overturning the Swaging Tool

Ensure that the swaging tool is always fixed in place to avoid the danger of injury owing to overturning of the swaging tool.

4.2 Installing the Swaging Tool

- Position the swaging tool at the desired position on the tool table of the press.
- Align the swaging tool.
The axis of the pressure ram (1) and pressure area center (2) must be perfectly aligned with one another.

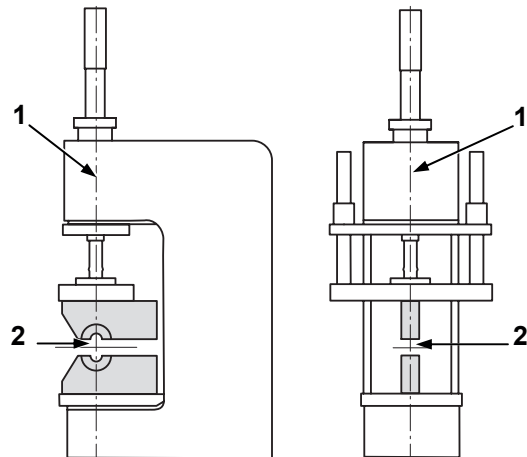

- Secure the lower half of the swaging tool to the tool table using the four clamping elements (3).
- Align the upper and lower halves of the swaging tool.
- Carefully lower the press onto the upper half of the swaging tool.
- Fasten the upper half of the swaging tool to the press plate using the four clamping elements (3).

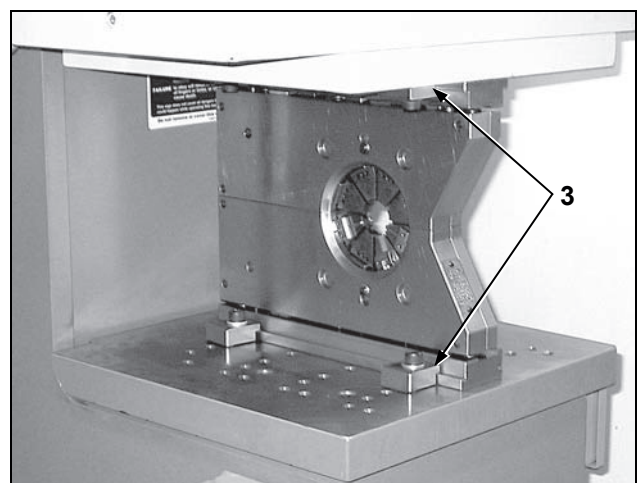

4.3 Testing Function



Warning

Danger of injury (crushing of fingers/hands) between upper and lower halves of the swaging tool.
 Danger of injury (crushing of fingers/hands in the area of the swaging jaws while pressing).
 Avoid any touching or other contact while pressing.



Warning

Danger of eye injury from metal splinters.
 Always wear safety glasses when working with the swaging tool.



Warning

Danger of hearing damage because of noise level.
 Always wear ear protection when working with the swaging tool.



- Check to ensure that the swaging jaws selected are suitable for the MCR being used. (The engraved size [ø in mm] on the swaging jaws indicates the smallest obtainable diameter of the MCR to be swaged.)
- Open the press.
- Insert the workpiece and relevant MCR.
- Start the press sequence. Place the press in set-up mode.
 Close the swaging tool only until the desired ring diameter is reached.
- Check the press result.
 Measure the external diameter of the pressed MCR. The diameter must agree with the prescribed press parameters.
 Increasing or decreasing the press stroke changes the ring diameter accordingly.

5 Operation



Warning

Danger of injury (crushing of fingers/hands) between upper and lower halves of the swaging tool.
 Danger of injury (crushing of fingers/hands in the area of the swaging jaws while pressing.
 Avoid any touching or other contact while pressing.



Warning

Danger of eye injury from metal splinters.
 Always wear safety glasses when working with the swaging tool.



Warning

Danger of hearing damage because of noise level.
 Always wear ear protection when working with the swaging tool.



5.1 User Requirements / Operating Personnel

- The swaging tool is to be operated by qualified, trained personnel only. Such personnel must also be familiar with the safety instructions and operation of the press being used. The minimum age allowed by law is to be observed.
- Before placing the swaging tool into operation, personnel authorized to work with the swaging tool are to have read and understood this technical description and to have been instructed concerning possible dangers.

5.2 Swaging with the Swaging Tool

5.2.1 Prerequisites

All parameters associated with the parts to be pressed must be known. The parameters are to be supplied by the technical staff responsible.

The following prerequisites are to be fulfilled:

- Swaging jaws relevant to the workpiece are to be installed.
- Positioning equipment, if required, is to be put in place.
- The external diameter of the MCR to be swaged must be known.
- The press stroke and pressing time must be known.

5.2.2 Operational Sequence

- Place the press is in its starting state. Move the upper part of the press to its upper position.
- Feed the workpiece radially (1) or axially (2). Ensure the MCR lies exactly within the swaging jaws (between the side edges).
- Start the press sequence. (The side edges of the swaging jaws prevent slipping of the MCR during the press sequence.)
- Remove the workpiece radially (1) or axially (2) as soon as the upper part of the press is again in its starting position.

- The guide and cover plates each have three M6 threads (3) for attaching workpiece rests or guidance elements.

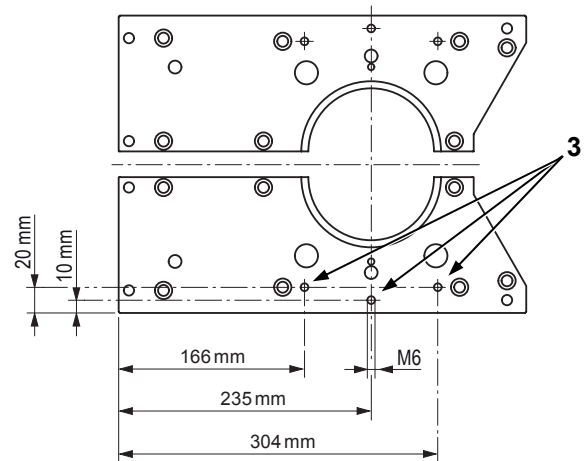
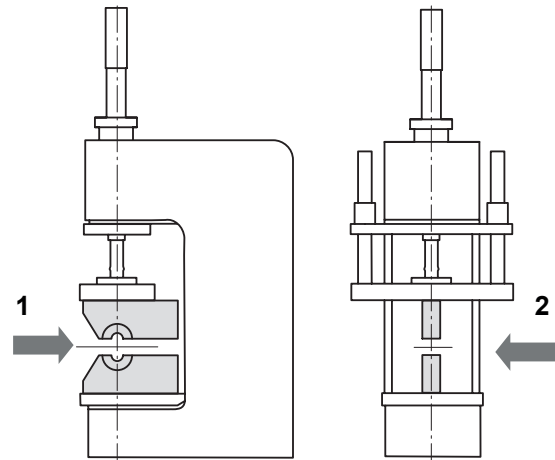

6 Maintenance

6.1 Cleaning

- Depending on the dirt accumulation, the swaging tool should be cleaned daily or weekly by using a cloth on all accessible locations.
Never immerse the swaging tool in water or other fluids.
- To protect against corrosion, oil lightly daily.

6.2 Exchanging the Swaging Jaws



Warning

Whenever the swaging tool is installed in or removed from a press, ensure that the press cannot inadvertently be activated. Safety instructions for the press are to be fully observed at all times.

You can exchange the swaging jaws whether the swaging tool is installed or not.

You can exchange the swaging jaws (4) either with a closed (1) or open swaging tool (2).

All swaging jaws are engraved with a size (\varnothing in mm). This size indicates the smallest obtainable diameter of the MCR to be swaged.

- Unscrew screws (3) and remove swaging jaws (4).
- Install the new swaging jaws.
If necessary, in the receptacle lightly strike the swaging jaws with a rubber hammer.
Tighten screws (3).

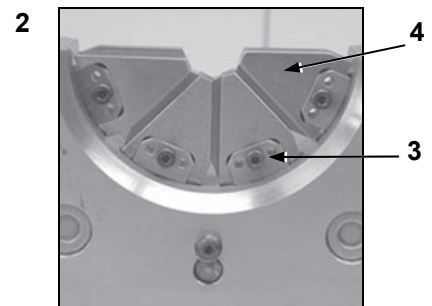
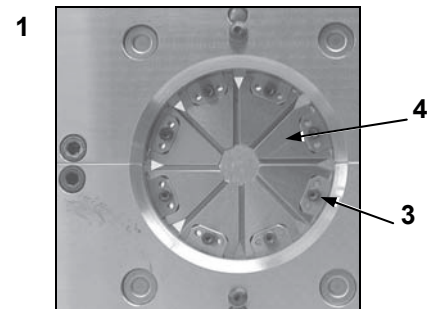

6.3 Check / Exchange Internal Parts

With careful monitoring and maintenance of the swaging tool, disassembly is only necessary to check for wear and to lubricate internal components. If malfunctions nevertheless occur, their cause must first be determined.

After 250,000 strokes, the swaging tool is to be opened and checked for defective internal components.

Swaging jaws-driving mechanism

The curve sizes (3) are positioned on roller bearings. These roller bearings are permanently lubricated and require no maintenance.

When the swaging tool is opened after 250,000 strokes for checking/repair, check and if necessary, replace the roller bearings.

Internal components:

Pos.	Name	Art. No.
1	Slider	13401313
2	Lever	13400506
3	Large Cam	13401314
4	Small Cam	13401315
5	Push Rod	13401318
6	Latch	13401320
7	Small Push Block	13401316
8	Large Push Block	13401317

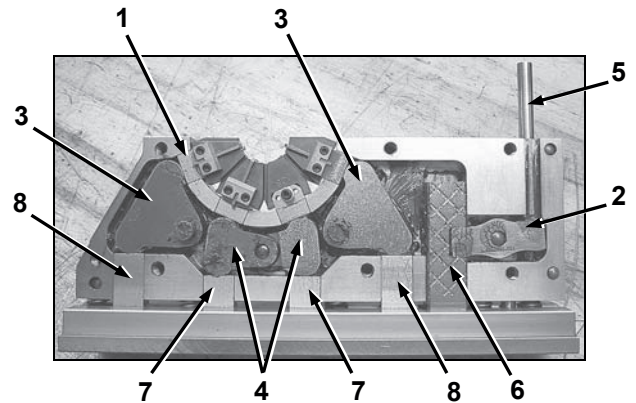

Swaging Tool Disassembly

The following sequence applies equally to the upper and lower halves of the swaging tool:

- Separate the swaging tool.
- Unscrew screw (1) M5x8 mm.
- Unscrew 7 screws (2) M8x20 mm.

- Strike back but do not remove 5 dowel pins (3).
- Remove cover plate (4).

- Place mechanism off to the side on the dowel pins.
- Dismount swiveling lever (5).
- Unscrew 2 pass screws (6) from the pressure plate.

- Take out pressure plate (7) from below.

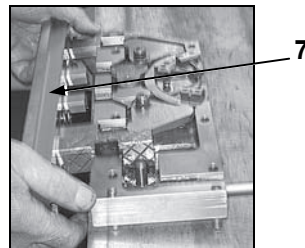
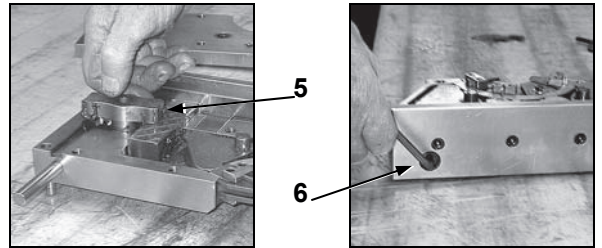
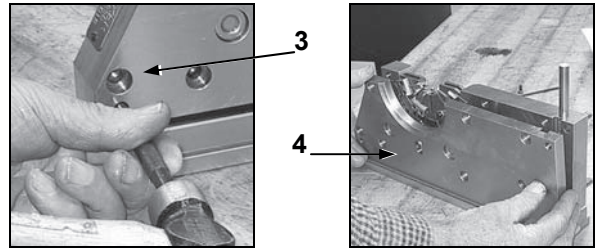
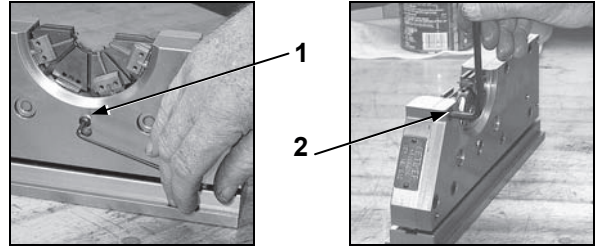

Installing the Swaging Tool

Before you install the swaging tool, grease all components with special grease, namely CASTROL MOLY GREASE. Equivalent greases from other manufacturers are also permissible.

6.4 Repair

Upon malfunction, defective mechanism, or suspicion of defects, immediately remove the swaging tool from service.

Never operate a damaged swaging tool under any circumstances.

Introducing any objects into the swaging tool is strictly forbidden.

No liability will be accepted for possible damage or injuries resulting from inexpertly executed maintenance or repair work.

Spare parts must meet the technical requirements specified by the manufacturer. Original spare parts are to be used. The most important and most common spare parts are listed in chapter 10, Spare Parts.

7 Malfunctions and their Elimination



Warning

If work is to be carried out on the swaging tool while it is installed in the press, ensure that the press cannot inadvertently be activated. Safety instructions for the press are to be fully observed at all times.

Malfunction	Possible Causes	Elimination
Diameter of the pressed ring is incorrect.	a) Swaging jaws are worn b) Defective internal component c) Incorrect press stroke d) Incorrect press pressure e) Inexact clamping of the swaging mechanism (misaligned)	<ul style="list-style-type: none"> • Exchange swaging jaws • Replace internal components • Set stroke correctly • Adjust press pressure • Check clamping (see section 4.2)
Swaging jaws remain hung up. Not in starting position when opened.	a) Excessive dirt accumulation b) Improper grease was used to lubricate the internal components.	<ul style="list-style-type: none"> • Clean swaging tool • Use only CASTROL MOLY GREASE or equivalent from other manufacturers. • Replace pressure spring in jaw supports.

8 Packing, Transport, Storage

8.1 Packing

- Check scope of supply against the delivery papers. If parts are missing, please contact Oetiker's customer service department.
- Save the wooden box for later storage/transport of the swaging tool.

8.2 Transport

- Use only the supplied wooden box to transport the swaging tool.
- Anytime the swaging tool is again to be commissioned, always proceed in accordance with chapter 4, Installing the Swaging Tool.

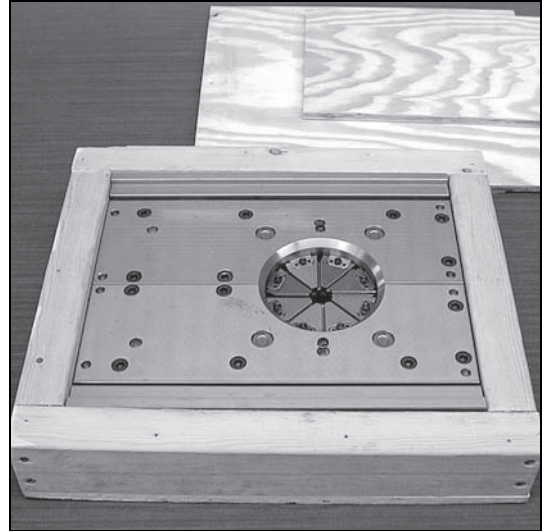

8.3 Storage

- Protect the swaging tool from environmental influences. Store it in a dry location at room temperature.

9 Disposal

At the end of its life, dispose of the swaging tool in accordance with your national regulations. We recommend that you contact a specialized disposal company for this purpose.

10 Spare Parts

The following table lists the most important spare parts that are available for repeat orders and reserve stock.

Please be sure to always specify the article number on the nameplate of the swaging tool when ordering spare parts.

Spare part	Quantity	Article No.	Comment/Type
Slider	8	13401313	
Lever	2	13400506	
Large Cam	4	13401314	
Small Cam	4	13401315	
Push Rod	2	13401318	
Latch	2	13401320	
Small Push Block	4	13401316	
Large Push Block	4	13401317	
Compression Spring	8	05004947	
Compression Spring	8	05004948	
Compression Spring	2	05004949	
Cam Shaft	8	13401319	BK 1212
Grease	1	08902550	Shell Retinax CMX

11 Statement of conformity

11.1 EC Declaration in accordance with the Machines Directive 2006/42/EC Appendix II 1.B

The manufacturer:

Oetiker, Inc.
6317 Euclid Street
Marlette, MI 48453

Hereby declares that the following product:

Product designation: Swaging tool OETIKER COMPACT XL
Product: Compact XL
Description: Tool for shrinking the Oetiker Multi Crimp Ring (150)

Satisfies the following requirements of the Directive:

See attachment "List of the satisfied requirements in accordance with Appendix I of the EC Machines Directive 2006/42/EC"

The commissioning of this product is prohibited until the machine or equipment into which this product is to be installed or of which it constitutes a component satisfies the provisions of all the relevant Directives.

The following harmonized standards have been applied:

EN ISO 12100:2010
Safety of Machines - General principles for design - Risk assessment and risk reduction (ISO 12100:2010)

Special technical documentation has been compiled for the product in accordance with Appendix VII Part B. Upon request, the manufacturer will provide these documents to the national authorities.

Name and address of the person who is authorized to compile the technical documentation:

Späni, Walter
Oberdorfstrasse 21
8810 Horgen

The Oetiker Group: www.oetiker.com

Headquarters Switzerland

Hans Oetiker AG
Maschinen- und Apparatefabrik
Oberdorfstrasse 21
CH-8810 Horgen (Zürich)
T +41 44 728 55 55
info@ch.oetiker.com

Austria

Hans Oetiker
Maschinen- und Apparatebau
Ges.m.b.H.
Eduard-Klinger-Strasse 19
A-3423 St. Andrä-Wördern
T +43 2242 33 994-0
info@at.oetiker.com

Brazil

Oetiker do Brasil Imp. e Com. Ltda.
Av. Hugo Fumagali, nr. 586 - Sala B
07220-080 Cid. Industrial Satélite
Guarulhos (SP)
T +55 11 2303 7486
info@br.oetiker.com

Canada

Oetiker Limited
203 Dufferin Street South
P. O. Box 5500
Alliston, Ontario L9R 1W7
T +1 705 435 4394
info@ca.oetiker.com

P. R. China

Oetiker Industries (Tianjin) Ltd.
10 Shuangchenzhong Road
Beichen High Tech Industrial Park
Tianjin 300400
T +86 22 2697 1183
info@cn.oetiker.com

Czech Republic

Hans Oetiker spol. s r. o.
Videňská 116
CZ-37833 Nová Bystrice
T +420 384 386513
info@cz.oetiker.com

France

Oetiker Sarl
Parc d'activités du Bel Air
1, rue Charles Cordier
77164 Ferrières-en-Brie
T +33 1 79 74 10 90
info@fr.oetiker.com

Germany

Hans Oetiker
Metallwaren- & Apparatefabrik GmbH
Üsenbergerstrasse 13
D-79346 Edingen a. K.
T +49 76 42 6 84-0
info@de.oetiker.com

Kurt Allert GmbH & Co. KG

Postfach 1160
Austrasse 36
D-78727 Oberndorf a. N.
T +49 74 23 87 70-0
info@allert.oetiker.com

Hong Kong

Oetiker Far East Limited
2210 Tuen Mun Central Square
22 Hoi Wing Road
Tuen Mun NT
T +852 2459 8211
info@hk.oetiker.com

Hungary

Oetiker Hungaria KFT
Vasvári P. U. 11
H-9800 Vasvár
T +36 94 370 630
info@hu.oetiker.com

India

Oetiker India Private Ltd.
N-14, Additional Patalganga
Industrial Area
Village Chavane, Khalapur
Rasayani 410 220
Dist. Raigad, Maharashtra
T +91 2192 250107-12
info@in.oetiker.com

Japan

Oetiker Japan Co. Ltd.
Kaneko Bldg. A
5-3-5 Nakamachi-dai, Tsuzuki-ku
Yokohama 224-0041, Kanagawa
T +81 45 949 3151
info@jp.oetiker.com

Mexico

Oetiker Servicios S de RL de CV
Ave. José María Pino Suárez 853 Nte.
Col. Centro, CP 64000
Monterrey, Nuevo León
T +52 81 8390 0237
info@mx.oetiker.com

Netherlands

Oetiker Benelux B. V.
Hertzstraat 38
NL-6716 BT Ede
T +31 318 63 71 71
info@nl.oetiker.com

Spain

Oetiker España, S. A.
Pol. Ind. Las Salinas
C/Puente, 18
E-11500 El Puerto
de Santa María (Cádiz)
T +34 956 86 04 40
info@es.oetiker.com

South Korea

Oetiker Far East Limited
Korea Liaison Office
Postal Zip Code 135-880
1401 LG Twintel 1-Cha 157-8
Samseong 1-dong
Gangnam-gu, Seoul
T +82 2 2191 6100
info@kr.oetiker.com

United Kingdom

Oetiker UK Limited
Foundry Close
GB-Horsham, Sussex RH13 5TX
T +44 1403 26 04 78
info@uk.oetiker.com

USA

Oetiker, Inc.
6317 Euclid Street
Marlette, Michigan 48453-0217
T +1 989 635 3621
800 959 0398 (toll-free)
info@us.oetiker.com

www.oetiker.com

